

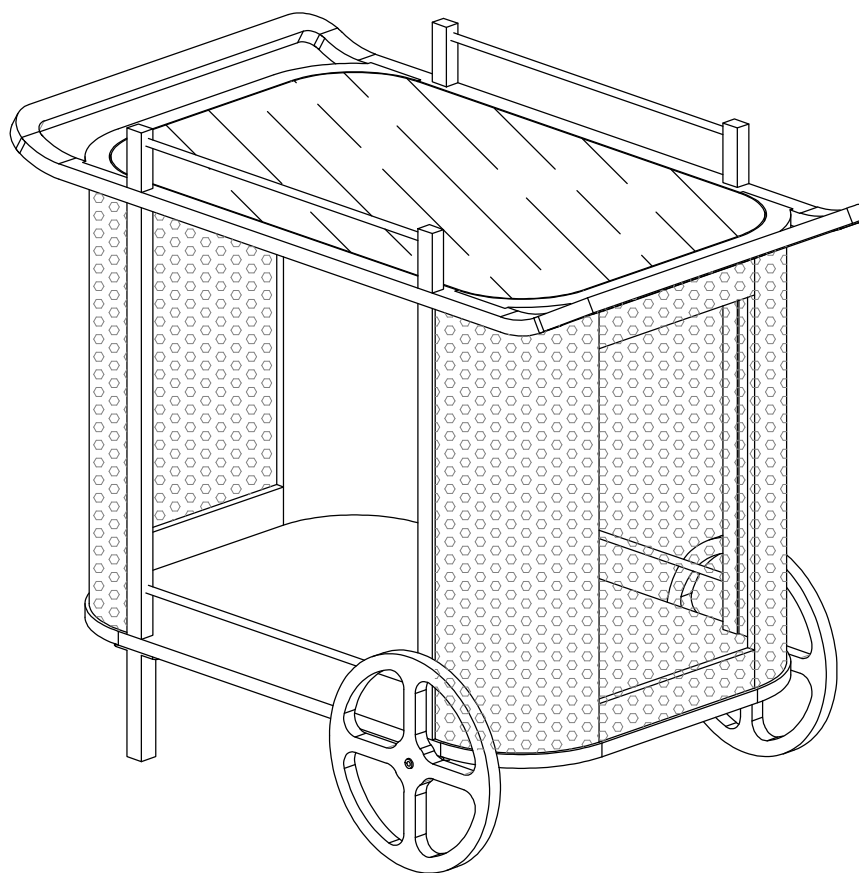



YUMA NATURAL RATTAN BAR CART

YUMA

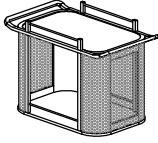

ASSEMBLY INSTRUCTIONS

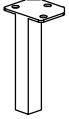

PARTS LIST

LABEL	PICTURE	DESCRIPTION	QTY
A		BODY	1
B		WHEEL	2
C		GLASS TABLE TOP	1
D		LEGS	2
E		WHEEL SHAFT	2

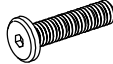
HARDWARE

LABEL	PICTURE	DESCRIPTION	QTY
F		Bolt M8x20	14
G		Washer Ø19xØ8x1mm	14
H		Wrench M4x60	1

BEFORE BEGINNING ASSEMBLY:



Read instructions cover to cover



Have two adults on hand for assembly



Do NOT assemble on flooring or carpet . Assemble on a clean non-marring surface (ex: packing Foam)



Save all packaging until assembly is completed

ASSEMBLY STEPS

STEP 1

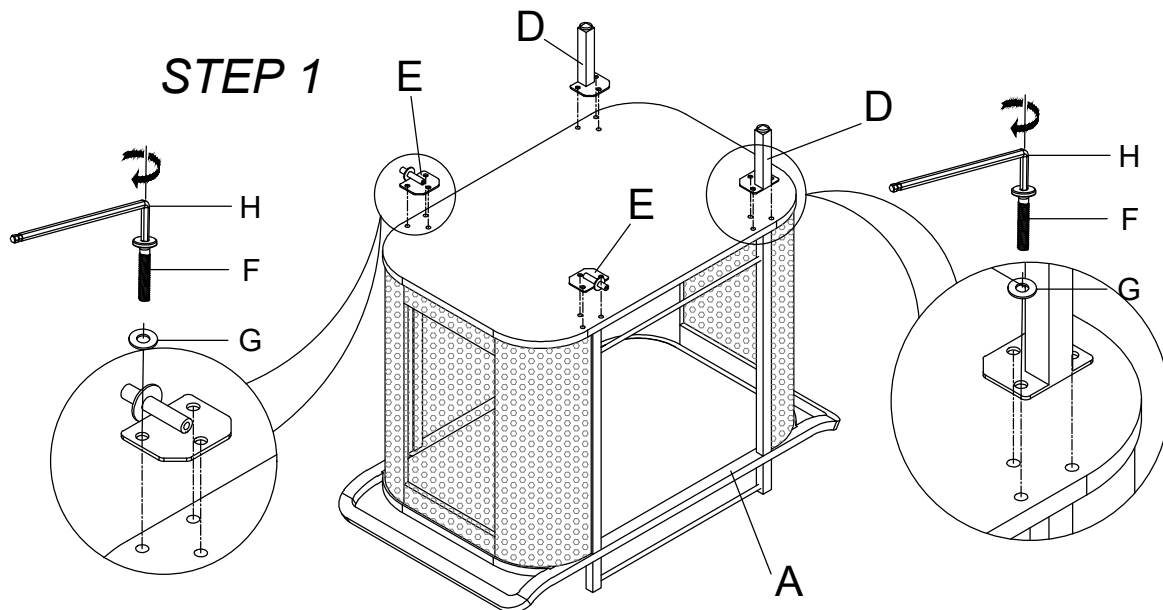

Position the body (A) top facing down with care. Install the wheel shafts (E) and legs (D) with the provided bolts (F) and washers (G) using wrench (H)

STEP 2

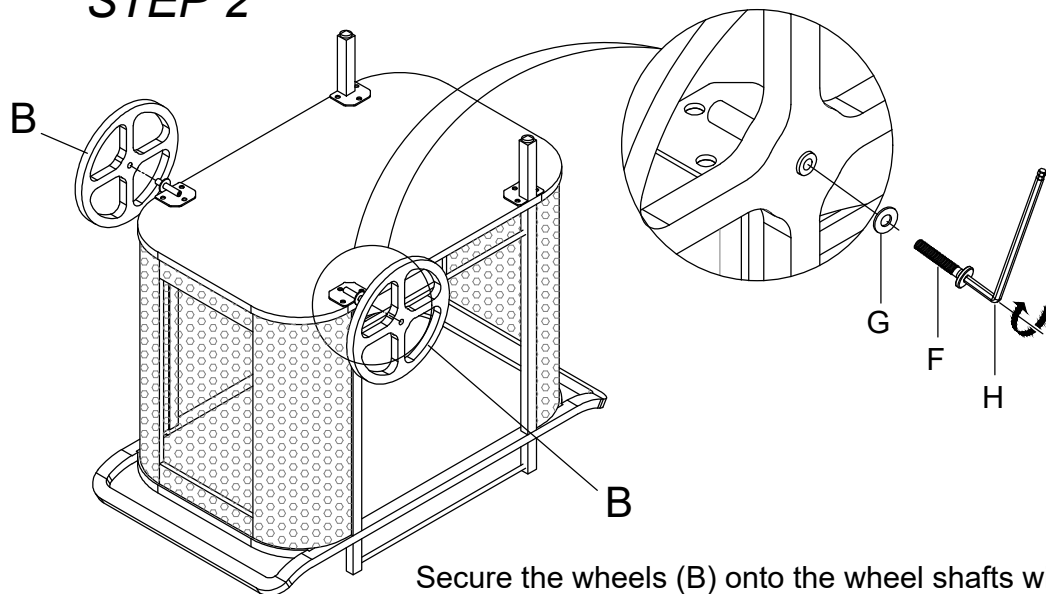

Secure the wheels (B) onto the wheel shafts with the provided bolts (F) and washers (G) using wrench (H)

STEP 3

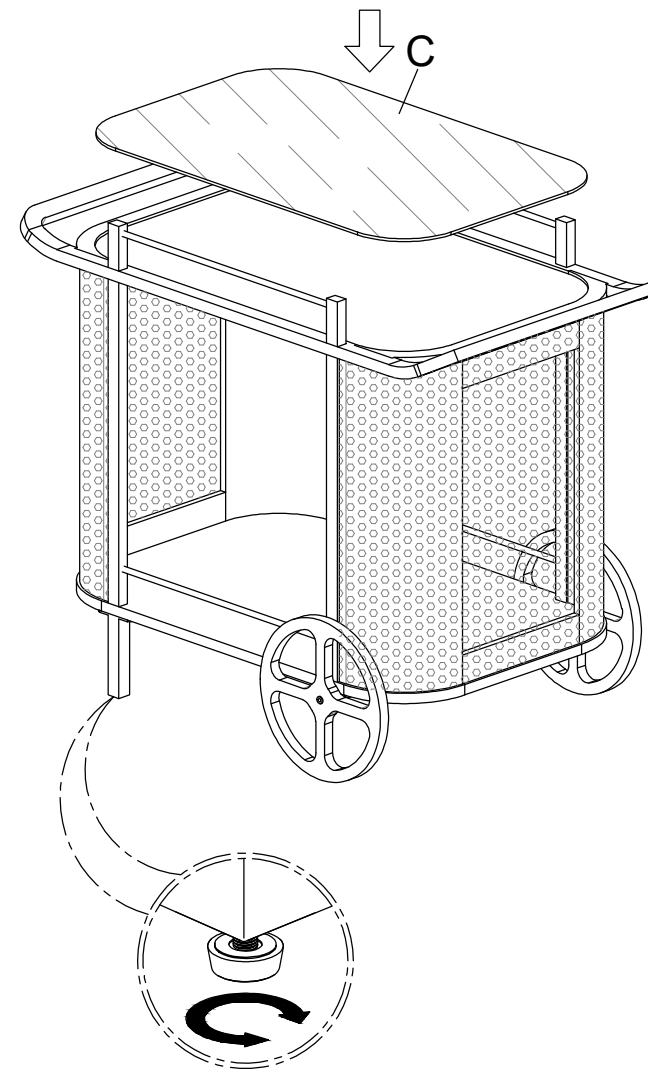

Turn over the cart with care and place on the glass table top (C). Adjust the leveler when needed.

CARE & MAINTENANCE



Do not put hot items directly on furniture surface.



Do not clean furniture with harsh cleansers or polish



Dust and wipe up spills using a clean, non-colored, lint-free cloth.



Stains may be removed with a mild soap solution and a damp cloth.



Do not place furniture under direct sunlight.



Do not place furniture near heating or cooling vents.



Do not write on furniture without a padded barrier to protect the surface.



Do not place furniture outside, for indoor use only.

**"Need a part? Call TOV at 516-888-3355 or
email service@tovfurniture.com"**